



User Manual

Compact Condensate Drain



Model: CON1xxxxx

Table of Contents

Notices	3
About Condensate Drains.....	4
Specifications.....	6
Condensate Drain Pack.....	8
Installation.....	9
Alarm	12
Maintenance and Cleaning.....	14
Warranty.....	19
Need help?.....	19
Installation and Service Record	20

Notices

Please read this user manual in full and carefully observe the notes and instructions before and during installation, operation and maintenance. The manufacturer cannot be held liable for any damage which occurs as a result of non-observance or noncompliance with this user manual.

Do not tamper with device. Should the device be tampered with in any manner other than a procedure which is described and specified in this manual, the warranty is cancelled and the manufacturer is exempt from liability.

The device is designed exclusively for the described application. Usage of this product in conditions not specified in this manual or in contrary to the instructions hereby provided is considered improper handling of the product and will void your warranty. The manufacturer will not be held liable for any damages resulting from improper use of the product.

This user manual should be read carefully by the technician / qualified personnel and the end user. **Once you install, use or maintain this product, you accept that you have read, understood and complied with this manual.** This manual should be kept with the condensate drain and made available to relevant personnel as needed.

Compressed Air Alliance endeavors to make the content of this manual correct and well stated, but is not responsible for omissions or errors and the consequences caused thereby.

Safety and Warnings

Ignoring the warnings can lead to serious injury and/or cause damage!

When handling, operating or carrying out maintenance on this product, personnel must employ safe engineering practices and observe all local health & safety requirements &

regulations. Improper operation or maintenance of this product could be dangerous and result in an accident causing damage to machinery or injury or death.

The manufacturer cannot anticipate every possible circumstance which may represent a potential hazard. The warnings in this manual cover the most common potential hazards and are therefore not all-inclusive. If the user employs an operating procedure, an item of equipment or a method of working which is not specifically recommended by the manufacturer he or she must ensure that the product will not be damaged or made unsafe and that there is no risk to persons or property.

NEVER CHANGE ORIGINAL COMPONENTS WITH ALTERNATIVES.



Compressed Air Safety

Any contact with quickly escaping air or bursting parts of the compressed air system can lead to serious injuries or even death.

- Do not exceed the maximum permitted pressure.
- Only use pressure tight installation material.
- The system must be depressurised during installation and maintenance work.



Electrical Safety

Any contact with energised parts of the product, may lead to an electrical shock which can lead to serious injuries or even death.

- Consider all regulations for electrical installations.
- The system must be disconnected from any power supply during maintenance work.
- Any electrical work on the system is only allowed by authorised qualified personal.

About Condensate Drains

Introduction

Anyone that owns and operates a compressed air system knows they generate vast amounts of condensate. Managing this moisture load is critical to the long term reliability and operation of the entire system and all the related equipment. Failure to do so results in downstream moisture events that can contaminate products, cause significant damage and creates long term reliability issues through corrosion and contamination.

Why install a condensate drain?

Contaminants can enter a compressed air system at the compressor intake or be introduced into the airstream by the system itself. Lubricant, metal particles, rust, and pipe scale are all separated and filtered out, but it's the drains that have to operate properly for the filters and separators to be successful in completing their task.

Condensate drains are possibly the least glamorous and most ignored component of a compressed air system but nevertheless, a most important part. No matter how much money you spend on that fancy new compressed air system, not spending a little effort with your drain choice could cause you no end of headaches and increased operating costs for years to come.

Condensate Drain Types

Drains come in many types and variants from no drain (yes, that is a drain choice), to manually operated, timed and Zero Loss/Level Sensor drains.

It is common to see timed drains used to remove condensate at critical points on the supply side of the system. As these operate on a set timer, they are adjusted for the worst case scenario and never looked at again, unless

there is a moisture event downstream. Valuable compressed air is dumped every time these types of drains operate resulting in increased operating costs and losses in system efficiency.

Zero loss drains are far more effective at removing condensate from compressed air systems while maintaining system efficiency. The level sensing ability of these drains means they automatically adjust to the amount of condensate being generated at any point in time. The alarm functionality alerts the appropriate personnel to a potential failure before the system becomes overwhelmed with condensate.

Where to install a condensate drain?

The most critical areas requiring a condensate drain are:

- Compressors – Depending on the model, your compressor can have anywhere from zero to four condensate drains.
- Refrigerant Dryers – These are often the most neglected of drains, a typical refrigerant dryer will have up to three condensate drains.
- Receivers – One of the most important locations is the wet receiver. Most receivers only have a single condensate drain, its failure can cause catastrophic downstream issues.
- Filters - Like receivers, filters only have a single condensate drain. Flooding a wet side filter will cause premature failure. Most dry side filters have a very small if any liquid loading capability so its important to keep them dry.
- Drip Legs – These are often the last line of defence before condensate reaches your equipment. As these are only operated when there has been a failure upstream, they are often neglected until it is too late.

What to look for in a condensate drain

Compressed air condensate contains particles that contaminate compressed air systems and potentially cause valve blockages. It is important to choose a drain that offers a large enough orifice. Avoid drains that have diaphragm type valve constructions, the diaphragm has a very small hole in it, that once blocked, the complete drain fails to operate.

Drains are also installed outdoors. IP65 (NEMA 4) insulation protection is therefore a minimum requirement. Avoid drains that do not comply to this minimum specification.

For long life expectations select drains that have FPM seals. FPM is the best suited for the aggressive make up of compressor condensate.

Servicing a drain must be straight forward and quick. Avoid drains that are not service friendly as this will cost more time during the maintenance interval.

Compressed Air Alliance's condensate drains

Compressed Air Alliance is a proud supplier of JORC drains. JORC drains are robust and designed for long life heavy duty applications.

Our electronic zero loss condensate drains automatically detect the level of condensate in the system and open /c lose accordingly.

Direct acting valve construction has proven to be the most reliable option for condensate draining applications. Combined with stainless steel moving parts, our drains offer a long life guarantee and are less sensitive to aggressive particles found in condensate.

The drain housings are constructed from robust coated aluminum and not from plastic.

This ensures that no damage is occurring during transport, installation, functional operation and the subsequent maintenance moments throughout the drain's working life.

High grade coil insulation protect the copper wire from overheating and top brand PCB components are applied on our electronic modules.

The FPM seals have been specifically selected based on their high and low temperature operation characteristics. In addition, FPM is the best choice for compressed air condensate as it is often quite aggressive.

The alarm contact allows connection of an indicator light or siren to immediately alert personnel of a condensate drain failure.

Servicing the drains is quick and simple. Maintenance can be performed on site without any special tooling or equipment. Low cost service kit packages are available for all drains.

Our condensate drains can be applied in both oil lubricated and oil free compressor applications.

Compact condensate drains

The Compact Condensate Drain is an electronic zero air loss drain with a normally open (N/O) or normally closed (N/C) alarm feature (potential free relay), suitable for smaller compressed air applications.

With an inlet connection height of 74 mm and a weight of only 0.5 kg, the Compact Drain offers an incredibly compact solution with unrivaled installation versatility and reliability.

The maximum compressor capacity of this drain is 10 m³ /min. (350 CFM) and typical draining applications include fridge dryers and filters - mainly due to its incredible compact size.

Specifications

Technical Data

Compact Condensate Drain		
Max. compressor capacity	Up to 10 m ³ /min.	Up to 350 cfm
Condensate	Suitable for all types of condensate	
Maximum drainage capacity	45 litres condensate per hour at 16 bar	
System Pressure	0 to 16 bar	0 to 232 psi
Temperature Range	+1°C to +50°C	34°F to +122°F
Valves		
Valve Type	2/2 way, direct acting	
Valve Orifice	2 mm	0.08"
Serviceable valve	Yes	
Inlet and Outlet		
Inlet Connection	1/2" BSP	
Inlet Height	74 mm	2.9"
Outlet Connection	1/4" BSP	
Outlet Height	15 mm	0.6"
Power		
Power Supply Voltage	230VAC or 24VDC	
Connectors	DIN 43650-B	
Alarm		
Alarm feature type	Contact output switch (voltage free) available in two versions: A1 and A2 A1 = Normally open contacts, closed when in alarm phase. A2 = Normally closed contacts, open when in alarm phase.	
Alarm feature specification	Max. 230VAC, max 4A, 1000VA or 200VDC, 100W and min 5VDC, 100mA	
Other Information		
Test Feature	Yes	
Environmental protection	IP65 (NEMA4)	
Integrated mesh strainer	Yes	
Dimensions	74 mm x 92 mm x 123 mm	2.9" x 3.6" x 4.8"
Installation Type	Permanent or temporary installation	
Maintenance Frequency	Annually	
Warranty Period	12 Months	

Dimensions

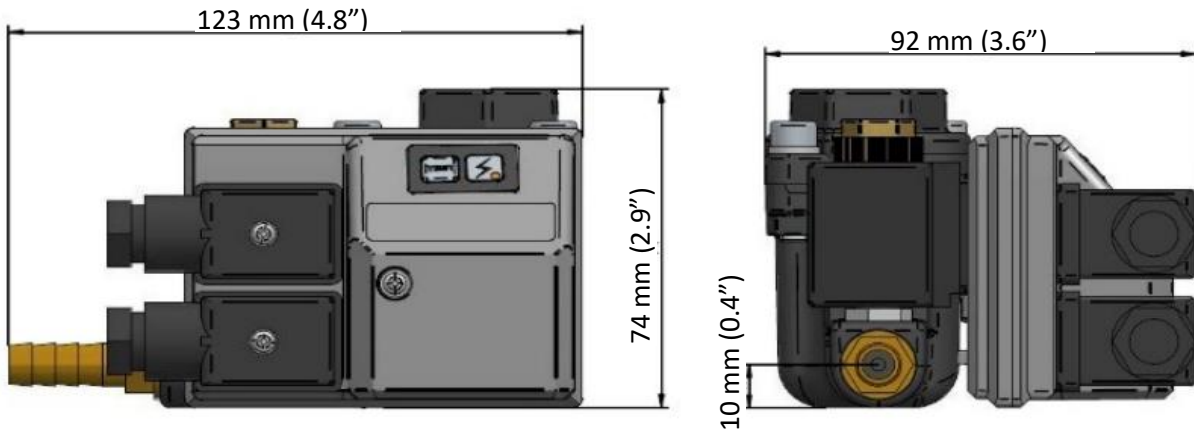

Parts List

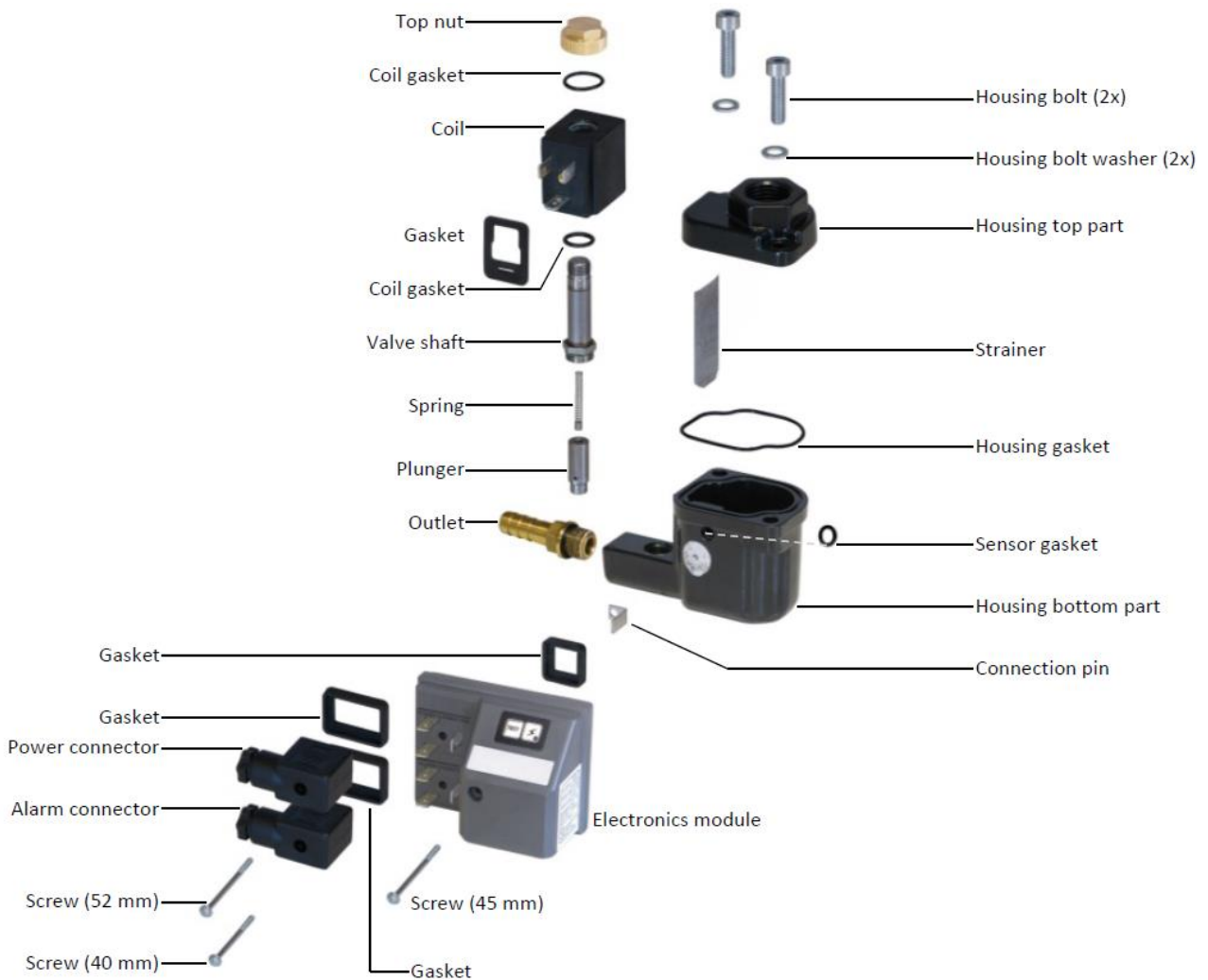

Condensate Drain Pack

Each condensate drain pack comes with:

- 1 x Compact Condensate Drain



Compact Condensate Drain

Instruction manual

Available on the Compressed Air Alliance website:
www.compressedairalliance.com/products

Optional Accessories

The following accessories are available for the flow meter. Talk to your local dealer or Compressed Air Alliance or pricing and other accessories.



M12 connectors – Male, female and Y-type



Data Cables

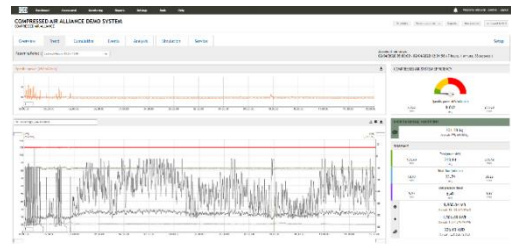

Data Acquisition and Analysis software

Installation

Installation Requirements



Correct Installation



Each condensate draining point should have its own drain.

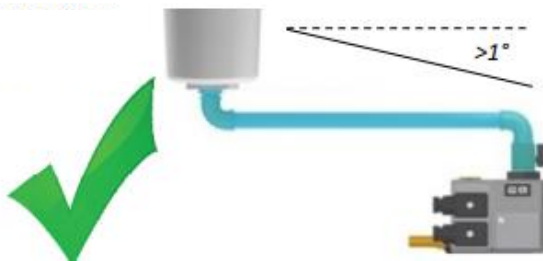

The 1/2" drain pipe must be horizontal or ideally at a downwards slope (>1°)

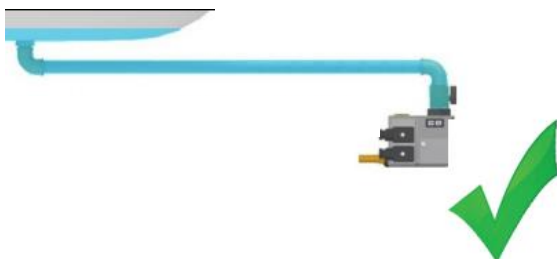

We advise to apply a 1/2" pipe diameter and 1/2" elbows to avoid an air lock



Incorrect Installation



Do **not** use one drain for multiple draining points

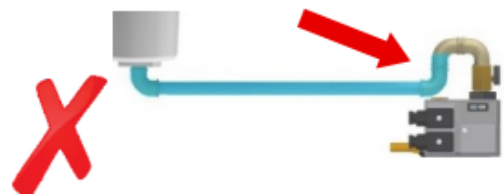

The 1/2" drain pipe must be horizontal or ideally at a downwards slope (>1°)

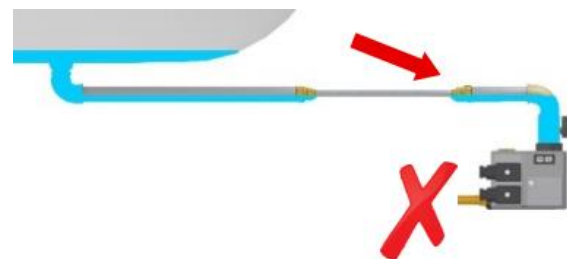

Do not narrow the feed pipe when installing additional adapters or piping, these may cause air locks.

Installation Instructions

WARNINGS!

- Incorrect installation can damage the drain or cause it to work incorrectly.
- Depressurise the system before installation or maintenance is carried out.

Tools required to install the condensate drain:



Wrench



Screw Driver



Ball Valve

Step 1.1 – Check the condensate drain

Unpack the condensate drain and visually inspect for any transport damage incurred after leaving the factory.

Before installing the condensate drain, make sure it is rated for your system (compressor capacity, system pressure, voltage, etc). Refer to the Specifications section above.

Step 1.2 – Depressurise the system

Depressurise the system before installation or maintenance is carried out.

Step 1.3 – Connect drain to your system

Locate a suitable condensate draining point in your compressed air system and connect your drain as illustrated (see image on next page).

- Use a wrench to install the drain properly.
- The use of a ball valve is advisable.

Step 1.4 – Connect outlet to an oil/water separator

Connect the outlet to an oil/water separator. We advise to use the nipple supplied with your drain. If it is necessary to use an alternative nipple, make sure it is of the correct thread (1/4" BSP). **Do not over tighten!**

Step 1.5 – Remove power connector

Unscrew the top power connector screw and remove the power connector.

Step 1.6 – Connect power

Connect your power supply cable to the connector. Check the wiring diagram (below) for AC and DC wiring. Make sure all gaskets are placed properly to ensure IP65 protection.

Step 1.7 – Replace power connector

Replace the top power connector and tighten the power connector screw (max. torque 0,3 Nm) as shown in picture 1.7 (below). Make sure all gaskets are placed properly to ensure IP65 protection.

Step 1.8 – Open Ball Valve

Slowly open the ball valve to restore normal system pressure. **The drain is now under pressure!**

Step 1.9 – Turn on power

Turn on the power supply. Press and hold down the TEST button to check the valve function. **A purging sound must be heard.**

Step 1.10 – Your condensate drain is now ready.

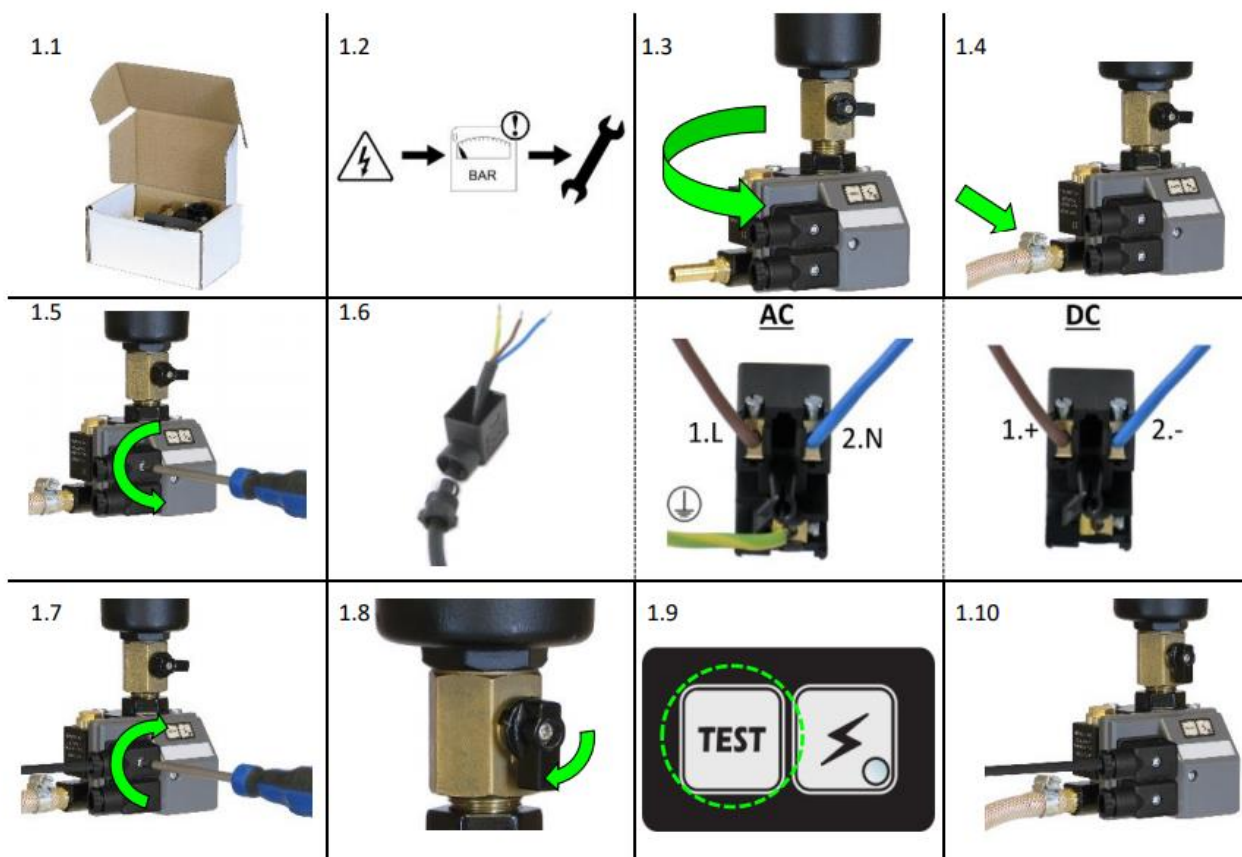

Alarm

The drain is equipped with an alarm feature. Alarm occurs when the valve has to open too many (>100) consecutive times without a pause. The reason for this may be debris (rust) particles blocking the valve, outlet, strainer or a sensor failure indicating a service necessity. It could also mean that your drain receives more condensate than it can handle. The alarm feature can be connected to an external alarm device with its own power supply. When in alarm mode the LED light on your drain will be flashing continuously.

Alarm Cycle

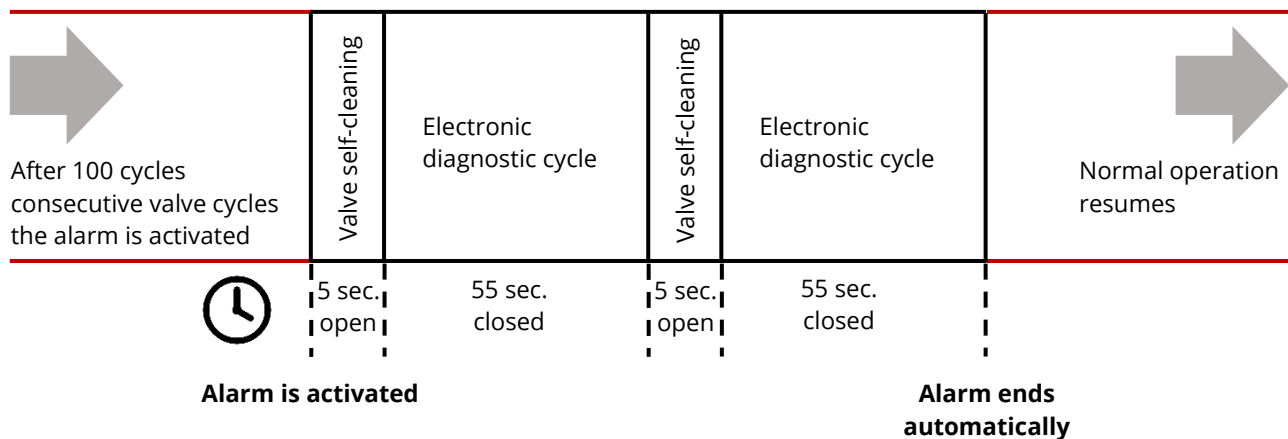

Optional - Connecting to an External Alarm

1. Unscrew the bottom alarm connector screw and remove the cap from the bottom alarm connector to connect the alarm cables to the alarm connector as shown below. Caution is required as you may be working with hazardous voltages!

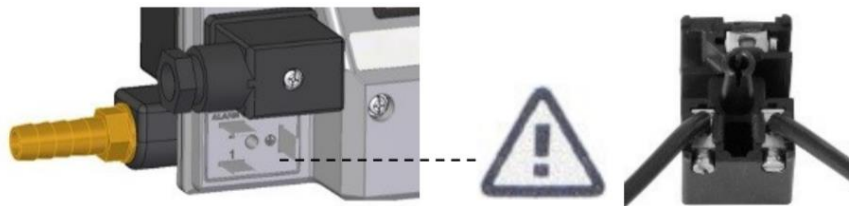

2. Connect the cable to your alarm device, any device of your choice can be applied i.e. a (flashing) light or alarm panel.

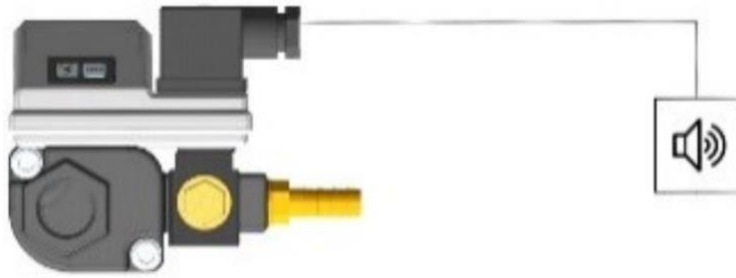

3. Connect your alarm device to a power supply. The alarm switch type is a 'contact output switch'. An external power supply is required as the alarm connection point on the drain works like a relay switch only.

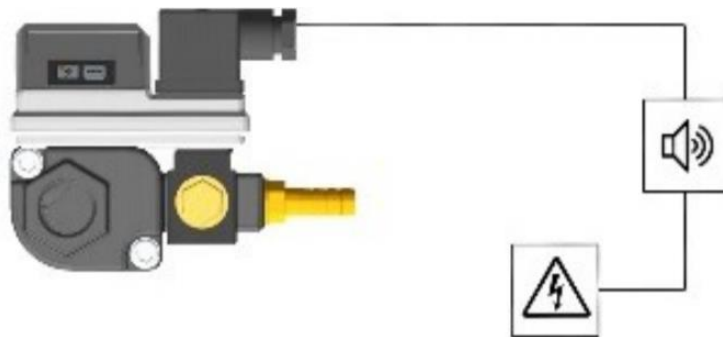

4. Connect the power supply to the drain alarm connector to close the circle. Replace the connector and tighten the connector screw (Max. torque 0,3Nm). Make sure the gasket is secured properly to ensure IP65 rating.

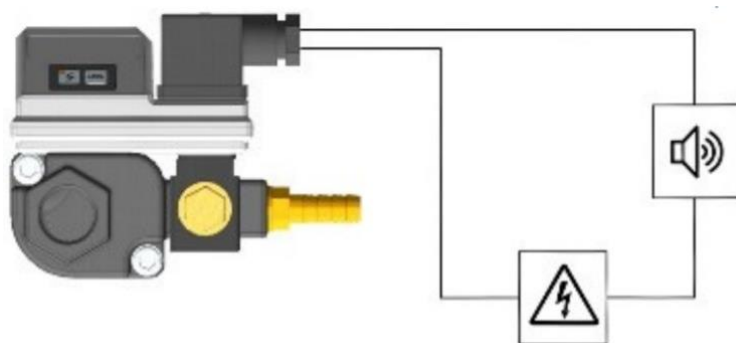

Maintenance and Cleaning

We advise to check this product **at least once a year** and replace serviceable parts when necessary.

Clean the strainer periodically to avoid possible blocking causes by rust and/or debris.

Check the valve function periodically by pressing the TEST button. A purging sound must be heard.

Maintenance Instructions

Please contact Compressed Air Alliance to purchase the service kit. Maintenance instructions are provided with the kit.

Cleaning Instructions

WARNING! Depressurise the system before installation or maintenance is carried out.

Note: These instructions are for cleaning the drain. If your drain requires maintenance, i.e. replacement of wearing components, please contact Compressed Air Alliance for maintenance instructions.

Tools required to clean the condensate drain:



13mm & 30mm
Wrench



Screw Driver



5 mm Allen / Hex
Key

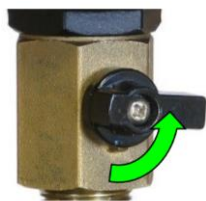

Step 1

Stop the condensate supply, i.e. close the ball valve which is installed in front of the drain.



Step 2

Press the TEST button to empty the drain of any residual condensate and to depressurise the drain.

**Step 3**

Switch off the electrical supply and remove the top power connector by unscrewing the top connector screw. Make sure the display is off to check if the power supply is successfully disconnected.

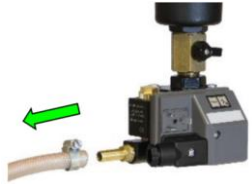
**Step 4**

Remove the outlet hose.

**Step 5**

Remove the drain using a 30mm wrench.

**Step 6**

Unscrew the electronics module screw.

**Step 7**

Carefully remove the electronics module. Make sure not to damage the sensor pin!

**Step 8**

Open the housing by unscrewing the two housing bolts using a 5mm Allen key. Remove the top part from the reservoir.

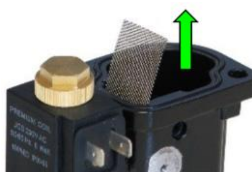
**Step 9**

Take out the strainer and clean it thoroughly.

**Step 10**

Unscrew the top nut and remove the coil.

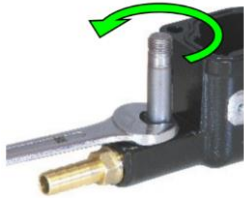
**Step 11**

Remove the valve shaft using a 13mm wrench.

**Step 12**

Clean all the valve parts and bottom part of the housing.

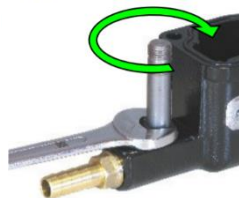
**Step 13**

Replace the valve parts and tighten the valve shaft using a 13mm wrench (max. torque 7 Nm).

**Step 14**

Replace the coil and gaskets. Tighten the top nut.

Make sure all gaskets are properly placed to ensure IP65 protection.

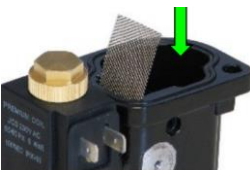
**Step 15**

Replace the strainer.

**Step 16**

Replace the top part of the housing and tighten the two housing bolts using a 5mm Allen key (max. torque 10 Nm).

**Step 17**

Replace the electronics module. Make sure you don't damage the sensor pin.
Make sure all gaskets are properly placed to ensure IP65 protection.

**Step 18**

Tighten the electronics module screw (max. torque 0,3 Nm).

**Step 19**

Reconnect your drain as illustrated. Use a 30mm wrench to install the drain properly.

**Step 20**

Reconnect the outlet.

**Step 21**

Replace the top power connector and tighten the top connector screw (max. torque 0,3 Nm).

Make sure all gaskets are placed properly to ensure IP65 protection.

**Step 22**

Slowly open the ball valve to restore normal system pressure.

The drain is now under pressure!

**Step 23**

Turn on the power supply. Press and hold down the TEST button to check the valve function.

A purging sound must be heard.

**Step 24**

Your drain is ready for operation!

Note: Check the valve function periodically. A purging sound must be heard

Warranty

Compressed Air Alliance provides a 12-month warranty for all Condensate Drains. The warranty covers material and workmanship under the stated operating conditions from the date of delivery. Please report any issues immediately and within the warranty time.

If faults occur during the warranty period Compressed Air Alliance will repair or replace the defective unit, without charge for repair labour and material costs but there is a charge for other services such as labour to remove or reinstall the instrument, transport and packing. Warranty repairs do not extend the period of warranty.

The following damage is excluded from this warranty:

- Improper use and non-adherence to the user manual.
- Use of unsuitable accessories.
- External influences (e.g. damage caused by vibration, damage during transportation, excess heat or moisture).

Other claims, especially damage occurring on the outside of the instrument (eg dents, marks), are not included unless responsibility is legally binding.

Need help?

Contact your local dealer.

Alternatively, contact Compressed Air Alliance via:

- Phone (Australia): 1300 558 526
- E-mail: sales@compressedairalliance.com
- Website: www.compressedairalliance.com

Installation and Service Record

Installation Record

Part Number (eg CON100001)			
Serial Number			
Installed by			Installed On (date)

Service Record

- We advise to check this product **at least once a year** and replace serviceable parts when necessary.
- Clean the strainer periodically to avoid possible blocking causes by rust and/or debris.
- Check the valve function periodically by pressing the TEST button. A purging sound must be heard.

Date	Description	Name



Compressed Air Alliance

Phone (Australia): 1300 558 526

E-mail: sales@compressedairalliance.com

Website: www.compressedairalliance.com